

PrimeProbe2[®] - Installation

Introduction

The PrimeProbe2 is positioned on the centre-line, sometimes termed axis, of the pipe (generally point of maximum velocity) or at 1/8 or 7/8 pipe diameter (generally point of mean velocity). Centre-line installation is often preferred as it often gives best accuracy. 1/8 pipe is used if the probe length cannot reach the centre-line. For best accuracy measure the pipe internal diameter.

Where to install

- The PrimeProbe2 must be installed away from any bends or hydraulic fittings. It must be installed with straight unrestricted pipe upstream of the sensor. The length of this straight pipe is defined in the table below and expressed in multiples of the diameter of the pipe. Downstream of the probe there must be a minimum of 5 pipe diameters of straight pipe.

Type of disturbance upstream from the measurement point	Minimum upstream straight length expressed in pipe diameters	
	For a measurement at the point of mean axial velocity	For a measurement on the axis of the pipe
90 degree elbow or a t-bend	50	25
Several 90 degree coplanar bends	50	25
Several 90 degree non-coplanar bends	80	50
Total angle convergent 18 to 36 degrees	30	10
Total angle convergent 14 to 28 degrees	55	25
Fully opened butterfly valve	45	25
Fully opened plug valve	30	15

This table is an extract from ISO 7145 (BS 1042) Section 2.2 1982 reproduced with their kind permission.

- Installation in a vertical pipe is not recommended. The probe may be used if the flow is in the upward direction and flow reversal does not occur. If installed in a vertical pipe the straight length of upstream/downstream pipe (as defined above) must be observed.
- The probe must be installed at 90° to the pipe, on the pipe centre line.
- The pipe must be completely full of water.

Measure internal pipe diameter

The probe is installed into the pipe through a pre-drilled 25mm hole via a 25mm ball valve. The internal diameter of the pipe is measured using a gauging rod.

1. With the valve closed connect the gauging rod to the ball valve. Be sure that measuring arm is aligned correctly with the pipe (see fig.1)
2. Fully open the valve and lower the gauging rod until it touches the bottom of the pipe. Rotate the gauging rod 180-degrees. Now lock-down the upper 'measuring-lip' (fig2).
3. Withdraw the gauging rod until it touches the top pipe wall. Lock-down the bottom 'measuring lip.' The distance between the two edges of the measuring lips is the internal diameter of the pipe (fig 3).
4. Rotate the gauging rod 180-degrees. Withdraw the Gauging Rod and fully close the valve (fig 4).

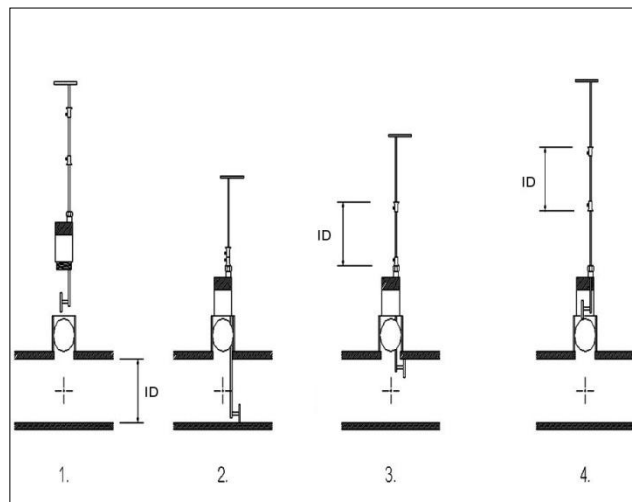

Install

1. For required insertion depth determine the distance between top edge of reference ring and bottom edge of converter box (called Z-value) as defined below. Secure the reference ring at this value.

Insertion depth	Z-value
1/8D	$L - (X + S + 1/8D + 110)$
1/2D	$L - (X + S + 1/2D + 110)$
7/8D	$L - (X + S + 7/8D + 110)$

$D =$ Internal diameter of pipe $S =$ Pipe thickness
 $L =$ see table below:

Insertion Length	L
150mm	500mm
300mm	650mm
500mm	850mm
700mm	1050mm
1000mm	1350mm

2. Ensure the anti-bounce chain is attached and secure.
3. Tighten the two side-screws.
4. With probe fully retracted screw the sensor sleeve into pipe.
5. Open the valve ensuring that it is fully open.
6. Loosen the two side-screws.
7. Slowly push probe through the open valve until the reference ring touches the locking collar.

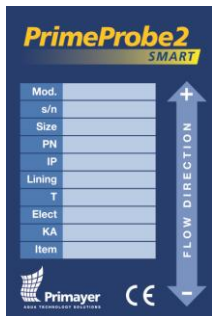

8. Confirm the direction of the flow of water. Refer to the top label flow direction indication and ensure flow direction is correct. Ensure the alignment bar is exactly aligned with the pipe axis ($\pm 2^\circ$).

9. Fully tighten the two side-screws on locking collar.

10. Open the ball valve and carefully bleed the pressure tapping to allow any trapped air to escape.

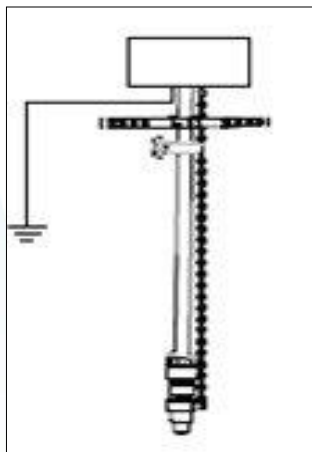

Ground the probe

For accurate results it is necessary that the probe and the water are both electrically at the same potential. To achieve this always connect the sensor to earth.

Switch-on

The Primeprobe2 is supplied in *Sleep Mode* to conserve battery life. Take it out of *Sleep mode* launch the **PrimeWorks** software and connect the PrimeProbe2 using the communications cable. In **PrimeWorks** select the *PrimeProbe2 - Wake up* menu option. The software will initiate communications to bring the probe out of Sleep mode. Upon completion of usage it is recommended that the probe is returned to Sleep Mode by selecting *Primeprobe2 – Sleep*.

